

ISSUE 10, 2001  
Last Issue of 2001

# The Keynote

*Newsletter of FISTS CW Club, the active chapter of the  
International Morse Preservation Society*



- Further the use of CW
- Encourage newcomers to use CW
- Engender friendships among members

“When You’ve Worked A FISTS, You’ve Worked A Friend”

**WALTS**  
By: ARNOLD, KY 4151

WYWA SE PA 81  
73

K42C  
GRU GUX  
73 TA

K4WRT  
GTC ATL 1

NEED QSP  
Bowersville  
Ovi (E)

Now, that is  
Just too Cool  
HIS ROCKS

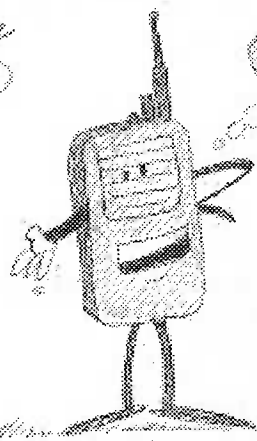

WYWA ATL 4

Beh  
WYA  
R AS

K4BEN  
Tui Pat

K1FP/MS

8PHT  
GEL

73 FRANK  
TU K4BEN GO

Tax for Biz  
Tom, Gru, Gux  
73 (E)

**WALTS**  
By: ARNOLD, KY 4151

K4FXG MS  
DU 4 ATL 1

AF4AS / 4RN  
PSE Ovi



THE QSP/TA  
Says a Strong  
THATS NOT

Ham Store  
open 24 hrs  
closed

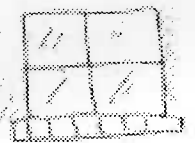

closed?, But it says  
open 24 hours ...

NOT ALL AT  
ONCE!

## HOW DO I...?

...**JOIN?** Membership is open to all interested in Morse code, irrespective of their speed and ability. Subscriptions = **\$15.00/year**. Under 18 = \$10/year. Family members may join FISTS at no extra charge—only one newsletter is mailed per household. **FISTS, P. O. Box 47, Hadley, MI 48440**

...**RENEW?** Send **\$15/year** (\$10/year for under 18) to FISTS, PO Box 47, Hadley MI 48440-0047. Your renewal date is on your mailing label — please look at it!!

...**SEND APP OR SAMPLE NEWSLETTER TO A FRIEND?** For a FISTS brochure, send an email to Joe Pardue, at <w5os@arrl.net> with their name, call sign, and postal address. For a sample Keynote, please send \$1 to defray postage. SASEs are appreciated. Joe's postal address is Joe Pardue, 29 Melrose Dr., Marrero LA 70072-5055. Applications are also on the FISTS Webpage.

... **ORDER CLUB SUPPLIES?** Irene Kott, WO8E, 44609 N. Bunker Hill Dr, Clinton Twp, MI 48038 has gold logo stickers 200 for \$3.50; "I Support KNOW Code" buttons for .50; Blue enamel /gold metal clasp-back logo pins \$2.50; Cloth patches are SOLD OUT; FISTS coffee mugs \$7.50; **FISTS Club T-Shirts M and L only**, \$9.00. Rubber stamps with FISTS logo for use with an ink pad (not included) for \$5.00. Please make checks out to FISTS, these prices **DO** include Priority postage.

... **GET AN UP-TO-DATE MEMBERLIST?** Send a SASE with \$2.00 to cover costs to Ed Hayes, N7CFA 2628 Lilac Street, Longview WA 98632. Lists are also available on the FISTS Web page.

...**Join the FISTS On-Line Email List?** For periodic Email updates on FISTS activities and information, send your Email address, callsign and FISTS number to Brian LaFontaine, W8BL, at his Email address: blafont@tir.com

...**GET/SEND FISTS QSL CARDS Via BURO?** Stan Reas, K4UK, runs the Buro. Send SASEs and FISTS member cards only (DX and NA) to him at 1020 Long Island Dr, Moneta VA, 24121.

...**SEND FISTS INFO TO A DX FISTS?** DX FISTS have a separate block of numbers; their Keynote is mailed from the UK. Send their info to Geo Longden, G3ZQS, at 119 Cemetery Rd, Darwin Lancs, BB32LZ; he'll send them a DX application.

...**APPLY FOR An OPERATING AWARD?** To apply for ALL AWARDS send a list of contacts (call, FISTS#, qth, date, band and power) to Dennis Franklin, K6DF, at 4658 Capitlan Drive, Fremont, CA 94536-5448. *Don't submit QSLs.* There is no charge to FISTS members for the awards, but SASEs are appreciated. Dennis handles ALL AWARDS now, do not send logs to England.

... **VOLUNTEER FOR or GET A CODEBUDDY?** Write to Terry Lohrey, 115 Meadowview Dr, Taylorsville KY 40071 or email <tllohrey@kih.net>. We need ELMERS, please volunteer to be a Code Buddy!! Code Buddy applications are available on line from a link on our web page.

...**GET MY PHOTO ON THE PHOTOPAGES?** Send a snapshot of yourself to Ken Kott, W8ROG, 44609 N. Bunker Hill Dr., Clinton Twp, MI 48038.

...**GET A COPY OF FISTS PRESENTATION** to give at a local club meeting? It's easy and fun! We send you everything you need for a snazzy 15-20 minute presentation. Contact Joe Spencer, KK5NA, 3618 Montridge Ct, Arlington TX 76016. email: kk5na@quadj.com

...**FIND THE WEB PAGE?** <http://www.FISTS.org>

...**SUGGEST IDEAS FOR THE WEB PAGE?** Contact Bill KK4KF at [KK4KF@LizardCop.com](mailto:KK4KF@LizardCop.com)

...**ORDER FISTS CLUB QSL CARDS?** For pricing info send SASE to WX9X at 1608 E. Lincolnway, Suite H - Valparaiso, IN 46383. A scan of the QSL card is on our FISTS Web page.

...**ORDER A FISTS CLUB ID BADGE?** Our club badge is blue, with FISTS logo in gold and your name, FISTS number, callsign, and Int'l Morse Preservation Society in white. \$8.20 postpaid from The Signman of Baton Rouge, 879 Castle Kirk Dr., Baton Rouge, LA 70808. A non-engraved, laminated club badge is available from Bruce Eichmann, W2BE, 204 E. Lake Blvd., Medford, NJ 08055. Cost is \$4.75, NJ residents \$5.00 because of tax.

...**IMPROVE MY CODE SPEED and MEET LOTS OF NEWFRIENDS?** Join FISTS! Get involved in the nets and activities! Volunteer to be a Code Buddy! Write an article for the Keynote about your interests! The Keynote, official publication of FISTS CW Club, is published approximately 10 times a year by Nancy Kott WZ8C, PO Box 47 Hadley MI 48440. WZ8C reserves the right to edit submissions for clarity, suitability and space limitations.. Comments not attributed to another are written by WZ8C. **Articles from the Keynote may be reprinted if credit is given to the original author.**

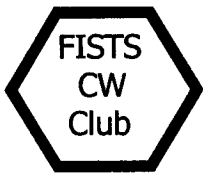

# The Key Note

The North American Memo Version by Nancy Kott WZ8C  
USA and DX member news and activities

International  
Morse Preservation  
Society - Issue 10, 01

Slow Traffic Net:  
Tuesday and Thurs-  
day 9PM EST on  
3.682

Slow RagChewing  
Group: Wednesday at  
9PM EST on 3.720

Volunteer Net Con-  
trols needed to run  
the Century Net on  
Sunday afternoon  
on 14.058 MHz

Saturday QSO Groups:  
2000Z on 14.058 MHz  
and 7.058 MHz at  
2300Z.

Sunday Slow Speed  
Chat: 21.158 MHz at  
1700Z

30 Meter calling fre-  
quency: 10.118

Please keep watch on  
the Novice subbands  
and frequencies ending  
in .x58 -- but PLEASE  
spread out. There have  
been over 7000 FISTS  
numbers issued now, if  
we all try and chat on  
these frequencies all  
anyone will get is a lot  
of QRM. Please be  
courteous of nets and  
QSOs in progress.  
Courtesy At All Times!

If you move please  
send your address  
change to WZ8C. It  
costs FISTS 60 cents  
for each undelivered  
Keynote due to  
address changes. This  
really adds up!

Page 2

Happy Holidays,  
FISTS!

A couple notes before  
we get on with The  
Key Note:

Awards Manager  
Dennis K6DF has a  
new email address. It  
is FISTS AWARDS  
@attbi.com. Dennis  
would like to encour-  
age you to submit  
your award applica-  
tions via email in or-  
der to cut down on the  
amount of paperwork.

His previous email  
address is no longer  
valid, so please make  
a note of this one. It  
will also be on the  
Web page [http://  
www.fists.org](http://www.fists.org) in case  
you lose it.

If you have any ques-  
tions about awards, or  
how to submit your  
application via email,  
please write to Dennis  
and he will be happy  
to explain it to you.

The FISTS patches  
are out of stock, so  
please do not send any  
order requests to Irene  
WO8E for a patch.

We are ordering a new  
patch which will look

FISTS CW Club

like the key logo that  
has been on the front of  
the Key Note, but it is  
not ready yet. When it  
is, we will put it in the  
newsletter and on the  
web page.

This is the last Key  
Note for the year 2001.  
Issue 1, 2002 will be the  
annual directory issue  
with an Active member  
listing and information  
on how to use the QSL  
bureau, and rules for all  
the Awards. Please hang  
on to it as a reference.

There are 10 Key Notes  
published a year. It is  
not a monthly publica-  
tion. Sometimes, due to  
reasons usually out of  
my control, two Key  
Note issues are com-  
bined into one, but they  
are generally mailed out  
every six weeks. The  
delivery time is at the  
mercy of the postal sys-  
tem. Most of the veteran  
FISTS members realize  
this, but it has been an  
issue of concern for the  
newer FISTS, so I  
thought I would try to  
explain it here. We use  
bulk mail to send the  
Key Note, which means  
it gets lower priority  
handling and the carrier  
has some discretion as

to the delivery time. If  
you feel your Key Note  
is not being delivered  
in a timely fashion,  
contact your post of-  
fice. There is a form  
you can fill out and  
they will do an inves-  
tigation into the situa-  
tion.

On the subject of dues  
checks: It generally  
takes an average of 6-  
8 weeks for a check to  
clear once I receive it.  
After you mail the  
check, it can take a  
week for me to get it. I  
often wait until the fol-  
lowing weekend to  
update the subscription  
files. We have a book-  
keeping service that  
does the official books.  
After I process them.,  
I take the checks to the  
bookkeeper about  
twice a month. She  
processes the checks,  
then takes them to the  
bank. So, you can see  
where this whole pro-  
cess can take a while. I  
know it can seem like  
forever when you're  
waiting to balance  
your checkbook, but  
your patience is appre-  
ciated!

Now, on with The Key  
Note.....

Issue 10 2001

Page 2

## Welcome to the New FISTS

#	callsign	First	State	sponsor
8508	N3XZA	LINDA	PA	
8509	W7BY	BOB	VA	K6NOF
8510	KC0IDI	REID	KS	KF8UN
8511	KB3GKY	JAN	PA	AA9BO
8512	KD5ALJ	HOWARD	MS	
8513	KF0K	TOM	MO	
8514	KM4ES	TOM	TN	
8515	WA2AKB	AARON	NY	AA9KH
8516	K7EMI	TODD	OR	KA7JSJ
8517	NG9U	NORMAN	IL	N9BOR
8518	N0SXX	GARY	CO	
8519	AB0SB	PAUL	MO	
8520	W7DO	Gary	WA	
8521	KD7BVO	Lynnette	WA	W7DO
8522	WA2KEZ	CRAIG	NJ	
8523	KG4PLA	DAVE	FL	KC0CCR
8524	KB1FUS	JOE	RI	K4PTU
8525	AF4AR	MIKE	TN	
8526	KC8RAN	JOE	OH	
8527	KD5JHE	JERRY	MS	
8528	K4BB	BOB	GA	
8529	KF9PD	MAURICE	IL	KC8LA
8530	WA9PLT	BOB	IL	K4IA
8531	WA3UMX	JOE	PA	
8532	KD5CMP	EARL	OK	
8533	WV8AH	ARNIE	WV	WB2FXK
8534	KA1ZT	KEN	FL	
8535	W9QP	JOHN	IN	
8536	WN1KXB	JOHN	NH	
8537	K6GVM	LYELL	CA	
8538	W4JZ	REED	TN	
8539	W4MEC	CHARLIE	NC	VE1RO
8540	KD5DIQ	PENNY	AL	WB4AWM
8541	N8LXR	TIM	PA	
8542	AE4TP	CHARLIE	SC	W4RTW/AE4RL
8543	N5AE	Richard	TX	
8544	KJ7HX	JERRY	OR	
8545	KC5BBP	Rick	TN	K0EDG
8546	KB1HBC	WALT	ME	K1CGZ
8547	KA3IXF	BILL	DE	
8548	WA4RJK	GERALD	AL	N1NM
8549	KE6CC	JOHN	CA	WA9PWP
8550	AC5VQ	CHAS	LA	
8551	K2ZF	JIM	NJ	WB2LMV
8552	KB4DJN	ELWOOD	VA	KD5KA
8553	KG4NYV	DUREN	SC	KE4COH
8554	W6MO	MIKE	CA	K6NT
8555	K6OWL	OWL	CA	
8556	WZ4L	WOODY	TX	K4UK
8557	AA2BN	JOHN	NJ	K8JD
8558	K0CPX	MILT	IA	
8559	KG5QU	DAN	TX	
8560	K9APW	DICK	WI	WB2FXK
8561	W8CE	AARON	OH	
8562	N0IK	LEE	ND	K0HFK
8563	AB5LV	Brandon	GA	WB2FXK
8564	WB2ZRR	LARRY	NJ	
8565	AK4G	BERT	AL	
8566	KL1BS	BOB	AK	
8567	W5OF	JACK	TX	N5VTV, KC5QIQ
8568	N2KZ	KARL	NY	
8569	N8MV	MATT	FL	
8570	N4ESS	RICH	FL	
8571	N2JJE	GEORGE	NY	
8572	KB1HBW	FRANK	MA	WB2FXK
8573	N4EKV	ADAM	CA	
8574	WD9EMF	VIC	IL	
8575	KG6IIP	RANDEL	CA	KB8LGJ
8576	N7BVY	STEVE	WA	
8577	W6FPS	RON	CA	
8578	WA1GEP	ANDY	MA	
8579	W1HVC	HARRY	MA	
8580	N6MFH	JOHN	OR	
8581	W6RLF	PAUL	CA	
8582	KD7HZO	JOHN	AZ	

### Call Changes

KC8FJW, John, is now W8VJW  
 KA8RIQ, Gary, is now N8OI -- # 2359  
 KC0KKN, Steve, is now AB0RP -- # 8290  
 KC0KLH, George, is now K0CNT.-- # 8506  
 N3MRQ, Anthony, is now AB2MU -- # 7282  
 KC0GTC, John, is now W0JRC -- # 8442  
 KC2GVG, Joe, is now WV2NY-- # 8091  
 KC5WYV, Andre, is now AD5FK # is 8170  
 XE2NJ, Joel, is now XE2P # 7452

### Issue 6/7 correction:

Member Number 8292 should be K1ES, not K1ED

## Keyer For Modulated CW (MCW)

Mike Greenfield/N9JIY/1282

This circuit is designed to operate most HTs. It's a fun project that encourages CW and homebrewing. It gives hams something new to do with that old HT. It can be used as a code practice oscillator, a MCW keyer, and a regular CW rig keyer exactly as it's first built!

Modulated CW (MCW) is created by injecting a "CW tone" into a rig's microphone input. So, it's not really CW at all. But it's a legal, recognized mode, and if you want to do code using 2M FM rigs, it's what you have to use. NOTE: On 2M, MCW is legal ONLY above 144.1mHz.

Most MCW generators are made to work with a straight key. But as operator speed goes up, patience with a straight key goes down, and you want something better. This MCW keyer works with a paddle. It's not iambic, but for the money it's tough to beat. It's based on the simple Ten-Tec "Budget Electronic Keyer" T-Kit No. 1553. You have to provide your own enclosure, switches, jacks, speaker, etc. Radio Shack items work fine. Contact Ten-Tec for kit price and availability. They were just \$12ea when I wrote this. A deal!

Assemble the Ten-Tec keyer kit per kit instructions, EXCEPT:

- \* For R2 use the 33k resistor
- \* For R12 use the 47k resistor
- \* Omit R17, C8, C9, and the speaker connections to the board
- \* Locate the R17 connection that goes to the IC U2 (pin9), and install a short insulated wire lead in this board hole. THIS IS YOUR LEAD TO THE EXTRA CIRCUIT SHOWN BELOW. The Extra Circuit has to share a ground with the kit board, too.

- \* Wire the Extra Circuit "ugly" on a piece

of perf board. The pots can be on-board trimmers. Install the whole mess in your project box, with speaker, connectors, switches, etc as needed. Note, that there are 2 keyed outputs: Regular CW from Q2, and MCW from the extra circuit. Once pots are set, you can probably leave them alone. You will want the keyer speed control shaft outside the box.

HT's usually have a stereo jack for auxiliary microphone input. This circuit works with MOST such HTs. Get a stereo plug that fits the jack on your HT. Wire the MCW keyed output ground side to the sleeve on the plug. Wire the "hot" side to the tip on the plug. No connection is made to the ring on the plug. Check your HT and microphone manual and wiring diagrams. This circuit can also be used with mobile 2M rigs, again check your manuals to see where to inject the tone and how to operate the Push-To-Talk for Transmit/Receive.

Adjust the MCW generator by listening to a separate receiver. Adjust the Tone pot to a pleasing sound that seems to "penetrate" well, and the Deviation pot for good volume without bleed into adjacent frequencies.

Try your 2M MCW rig station-to-station simplex. You'll discover you can copy MCW code in poor conditions where voice can't be heard at all. An added benefit, and another reason to use this setup.

*See diagram  
on page 18*

## Diamond Ramblings

By Craig "Buck" K4IA

I was first licensed in 1964 as WN4TUF, a rock-bound (XTAL controlled) Novice. I remember many a night, cans on head, straining to pick a CW signal out of the short wave stations and static on 40 meters. Later, a General class license brought the world to me as I bobbed around the big guns on 20. Sideband was the hot new mode, but I could care less about "duck talk." CW was where it was at.

College, family and career QRTed me in 1970. For 29 years, I had nothing to do with amateur radio. The Y2K scare got my wife concerned about communications and she suggested (much to her regret) that I get back into the hobby. Needing no further encouragement, I dove in.

After 29 years, the code came back immediately. Like riding a bicycle I suppose, one doesn't forget. CW is still my favorite and almost-only mode. I joined FISTS on November 30, 1999 and it was a great honor to get my Diamond, #64, on November 15, 2001. I am sure I didn't set any records but maybe I can pass a few tips to help you along the way. Every day I hear the lament that the numbers get harder as you go along. True, but I have added 24 new points in the last week. Here are some ideas:

### POLISH YOUR SENDING

No one wants to listen to sloppy sending. It doesn't matter how slow or fast you send, is it readable? I am reluctant to answer a station I can't understand. There were two great articles about alphabet soup in the Keynote (Issue 8/9, 2001). Listen to yourself critically. I know that I have a problem dropping the last dit in a string. It is frustrating but I am working on it

Are your letters formed correctly? Dah di di dit can be TS, B, DE or NI. If you're sending text, I will probably figure out what you meant, but if it is a call sign, I am lost. Try this one: Dahdit Dahdit Dahdit dit dididit dididit didit. Pretty musical, but did you recognize it as "Tennessee?"

How are your word spaces? Running words together is very confusing. If I send you

"de K4IA K4IA K," does it come across as K4IAK or AK4IA? This gets old after several repetitions. I've heard CQs I couldn't answer because I couldn't get the call right.

I prefer what I would call extended Farnsworth. Fast letters with big fat spaces. I believe it is the easiest to copy and communicates at a fair clip considering there are fewer callbacks. And while I am on the soapbox, what is this with all the repeats? I don't need to hear "Ur RST RST RST is 599 599 599." Depending on conditions, "Ur 599" does the trick in a lot less effort.

**DON'T BE A CREATURE OF HABIT**  
Why not? Because everyone else is.

If you always hang out at 14.058 at six in the evening, you are going to miss the guy who always listens on 21.058 at noon. Try to fit in different propagation patterns and different times of day. Work the bands. Work the WARC bands. Work the ones that don't seem open. As I write this, I have been listening to 10 meters for 15 minutes without hearing a signal. I put out one CQ and bagged a new one in California. Check the novice frequencies. Call CQ FIST.

Not all FISTS hang around the 58's calling "CQ FISTS." You shouldn't either. Hint: Many QRPers are also FISTS. Try listening on the QRP calling frequencies. Use your member roster to identify the hidden FISTS.

Vary your speed. If you always call CQ at 25 wpm, there are plenty of people who won't answer. They don't want to be embarrassed when they have trouble keeping up. I call around 20 wpm but drop down to 10 wpm if there are no answers. Many times, the slower CQ will bring up a contact that I suspect was lurking there all along.

**KEEP A CONTEMPORANEOUS LOG**  
I use a clip board to hold my note paper. The last sheet on the clip board is the CC log sheet available on the FISTS website. My computer log checks for dupes and if I score a hit, I write it on the CC sheet immediately. No one is forgotten and there is no paper work to catch up on later. It is done. At the end of each sheet, I write

in the total and reload. The running score keeps me motivated. Figuring about 60 points to a page, it takes a little less than 17 sheets to make Diamond. Piece of cake.

And, don't forget to fill out your QSL card at the same time. Contemporaneous QSLing is not a chore. I have sent a QSL card (via the fantastic FISTS buro) to every one of my FISTS contacts who said they would QSL.

### GET A MEMBER LIST

The FISTS membership roster is updated regularly and published on the FISTS website. It also comes in the January Keynote. I keep mine on the desk and check it regularly. By year-end, my list is worn out.

As I said before, not all FISTS are on the 58's. I have made many FISTS contacts in other parts of the band; often with stations who were surprised when I gave my FISTS Number. I knew they were a member because I saw them on the roster. The number formatted roster can also serve as a dupe check if you don't use a computer log.

That's all for now. Good luck on your Diamond. As for me, I am on my way to Double Diamond. You say there is no such award? I hope the Club will have one by the time I get there! 73 es DX Buck K4IA

### How do you design your antenna?

Generally speaking an antenna is basically a two-element device to which an RF potential difference is applied to the two elements. Yes, there are loop antennas but that's another discussion. In a standard 80-meter Dipole antenna, the equal and opposite potentials are applied to the two metallic legs (usually wire), each about 65 feet long.

Now let's modify the Dipole by removing one of the metallic wire legs. In its place we will put up a 4-inch diameter PVC pipe 65 feet long (with rope supports) and fill it with damp soil. Then we will insert a 6-foot metal rod in the end of the PVC into the soil and attach the exposed end of the rod to our feed line where the metallic wire was removed. This is about equivalent to

constructing a vertical antenna and using a ground rod in lieu of radials. How well do you think this antenna will work? It's a first cousin to the "One Hand Clapping" routine.

Back to the full metallic wire dipole we started with. Modify it by bending it into a 90-degree angle at the feed point with one wire pointing straight up. Dig a trench in your yard 65 feet long and bury the other wire. Now you have a bottom fed vertical with a buried radial. Since the soil has a relative high resistance compared to wire, the RF currents produced between the two metallic elements are somewhat attenuated. This explains why elevated radials, or radials placed on the surface of the earth, work better than buried radials. Nothing like having half your antenna underground.

The Unipole antenna just has a hard time developing a difference of potential in respect to nothing. Maybe that's why Dipole antennas work so well. The vertical antenna is usually equivalent to a bent dipole. I have discussed just a basic two element antenna. It is a complex subject and this is just a speck of dust on the surface. Think about the two elements when you put up the wire, especially vertically. Have fun, Frank, N3ZOC

### Need More Wallpaper?

Our club, VE3HRC FISTS number 7300, will be operating on Field Day. We plan to operate on all bands and all modes. The following FISTS will be operating CW John 6261, Michelle 5760, Jeff 5793 and Chris 5761. Our club has a Free CW certificate, except for \$2.00 postage, that is easily earned.

All that has to be done is contact Heritage Amateur Radio Club and three of it's members using only CW mode on any band and then mail in a copy of your log clearly showing person contacted date and time. Full rules and other modes can be found at <http://www.geocities.com/harcawards>. Thanks, Chris VA3SYQ 5761



## **You Can't Please All The People All of the Time.....**

Every once on a great while, I'll get a letter like this one: "I have enclosed me dues for one year in FISTS. I decided to give it one more year, although there seems to be a considerable lack of interest amongst members and only a small number of FISTS remain active. I know some suggestions have been made that might help to peak FISTS activity, but those suggestions seem to have fallen on deaf ears.

"The first issue of the Keynote is handy because it contains a list of all the current members. Beyond that, the Keynote has become a forum for self-appointed experts bent on imposing their operating techniques upon the rest of us...The magazine has degenerated into a rag filled with pages of bitching and bellyaching and I seldom read past the inside of the front cover."

**However, for every letter like that one, I receive about 100 like this one --**

"Renew me for another year - enjoy the magazine very much and love to read articles by other members. Some of the older CW ops have a wealth of information on everything from antennas to operating techniques - plus tons of interesting stories to tell. I would like to ask them to sit down and share with us newer ops (not always younger ops, hi hi). I started out in radio as a curious SWL, learned a little about antennas, then got bit by the CW bug. If there was no CW I probably wouldn't have bothered getting a ticket. I enjoy it very much and am looking forward to more ops putting on the Elmer hat and sharing with us new guys. Al KB2WYO"

"Here is a two year renewal for membership in a great organization. FISTS has helped me develop my CW skills to the point that I really love CW. I rarely connect the mic to my rig! Please keep up the good work. Steve N2WJ"

"Enclosed is a two year renewal. Four and a half years with FISTS and still having a ball. Dave N6FE"

"A big thank you for all your hard work. I look forward to each issue of the Keynote and read it from cover to cover. Believe me, fellow FISTS, code is the only way to go. Jiggs WA0FGV"

"I enjoy the Keynote so much it just didn't seem possible that renewal time was here. Let me thank you for all you have done and are doing for amateur radio by defending and promoting the use of Morse code. You are doing an excellent job and those of us that would like to do more, but simply are not able, certainly do appreciate your hard work and the sacrifices that you surely must make.

"There are times when I am very disappointed in the trend that amateur radio has taken. I believe that through organizations like FISTS we can at least slow the trend, and restore the tradition, comradeship, professionalism and helping-hand attitude that is often missing in amateur radio today. It seems to me that many people simply do not understand the relationship between Morse code and amateur radio. Fortunately, there are many that do - just look at the Keynote letters that describe the "art" and tradition of using code and, more importantly, the satisfaction and excitement of making that contact. Mac WN3C"

"I want to you know that I have really enjoyed belonging to the FISTS organization. The FISTS members I have contacted all seem to be great people and enjoy not only exchanging numbers, but also a little conversation. You have to be congratulated on publishing a great monthly newsletter. I look forward to receiving it every month. Thank you! Dick K7RRR"

"The members of FISTS are the BEST! I have to extend credit to FISTS for promoting on-air friendships and the encouragement to upgrade through practice, practice, practice! Jeffery N9ZUT"

"Just got my Keynote and realized that I was about to expire, membership-wise. A money order is going out of here in the morning via postal mail. I hope it arrives in time. My time is

up on the 4th of May. I don't know the policy but FISTS is the only club I have renewed membership in for years. In addition to the web page, the Keynote alone is worth the price. Only newsletter that enters the house that is read cover-to-cover. I have been in the process of building my "dream" CW QRP station for the past year. Living in apartments is a real challenge. I should be ready for portable/field ops by just moving my base station. Anyway, the money is in transit so please don't drop me. 73 de Carl K0BZV #7432"

"I want to be sure my subscription has not expired. The cover of the Keynote was outstanding with the American flag! The motto still holds, "When you've worked a FISTS, you've worked a friend." Sincerely, Woody WB4ZOF"

"Because I am extremely sensitive about being shown to an attractive young woman that a \$15 membership fee can interfere with my social standing in FISTS, I have checked our sofas, easy chairs, car seats, and pockets of my other pair of trousers for the change necessary to add up to \$15.

Because hunting was not...repeat...NOT GOOD, I have fallen into a mental depression that I cannot explain to my wife, children, friends, or political hangers-on.

However, before losing all hope, and selling my coax feedline in a fit of angst, the Wolf at our door had pups, and I have been able to sell these pups to several good hearted animal lovers...which makes it possible for me to forward the enclosed check to you.

I promise to do better next year for I am preparing a sign "Will send Morse code for FISTS membership!" It will be neatly done, placed on a yard arm sign on my front lawn...with a 3 legged camp stool adjacent for my support while I attempt to make eye contact with the YUPIES in my neighborhood. 73 Carl W2RWH"

You FISTS never fail to crack me up, and keep my spirits up as well. I do appreciate all the kinds words, and CONSTRUCTIVE criticism. FISTS is far from dying, POB 47 overfloweth, and the QSL Bureau is doing a booming business.- Nancy WZ8C

## QRP With John Shannon K3WWP Column #48

I've had this column sitting in the can (as they say in the movie and broadcast industries) for a while now, so some of the material is a bit old, perhaps. However it still applies, so I might as well empty the can and have Nancy publish it this month.

This month some random thoughts about QRP. I get a lot of these thoughts as I'm sitting at the rig waiting to work a DX station or while my CMOS Super Keyer II is busily calling CQ for me. Unfortunately I don't write them down as they occur to me, and have to recall them from memory as I write the column like I'm doing now.

A couple days ago, I managed to work D68C on 15M. Now the QSO was so easy that I thought maybe it wasn't really the DXpedition, but just someone pretending to be D68C. Well I just now checked their on-line log, and my call is in there, so I did work the Comoros for my QRP country # 193 worked. This leads me to a couple of the things I had been thinking about to put in this column.

Often times the QRP station may not be sure if a DX station logged him correctly or not. I often will get something like K3WP? TU 599: I'll then correctly send my call two or three times and my exchange. Then the other station will respond with QSL 73, but never repeat my call correctly. Now how do I know if he ever made the correction or not. A high powered station will often be able to come back to him again and ask if he has the call correct, but with QRP it often isn't possible to do that. This is where the on-line logbooks come in handy. You can check to see if you have been logged correctly or not. If so, great and congratulations. If not, you can try to work the station again, or contact them via land mail or eMail and explain they may have logged you incorrectly. If you provide the correct time and other details of the contact, they generally will believe you and

make the correction. If you're in this situation, you can check sources of on-line logs from well over 2500 stations via my web site address given at the end of this column.

The next point is why did I work D68C so easily with my 5 watts and dipole. There are any number of reasons, some or all of which may apply. First the D68C operation has a group of top notch operators who have spent their ham careers digging weak signals out of the noise and clamor of a pileup. Also they have top notch receiving equipment and antennas at their site. However perhaps the most important factor is propagation. If you happen to try for a remote DX station at just the right time when all of the places that your signal bounces off (well, actually refracts through, to be technically correct) the ionosphere are in just the right state, your signal will make it through.

It so happens that in the direction of the Comoros from my location, there is a high hill which means that to clear that hill my signal must take off at a higher angle than I would prefer. As a result it will be forced to take one, two, or even three extra hops to get as far as the Comoros than if I lived on top of that hill with a flat horizon in that direction. As a result, the southeast part of Africa is very hard for me to work. However, and this is my point, I was there at the right time when conditions were just right, and even though my signal undoubtedly was attenuated quite a bit on its way there, I was heard and copied for a QSO rather easily.

Keep these things in mind if you do get discouraged when trying to work someone. Just keep trying and when conditions are just right you will be able to do it.

Along the same lines in working DX, I'm finding it harder and harder to locate a new country to work as I approach 200. The main reason is my way of doing things. I don't like to use packet or internet spotting to locate DX stations for me. I prefer to tune around the bands and find them myself. I believe it is much more rewarding doing it my way than to watch the spotting networks all day, and when a new DX station shows up to go and try to work it. Only one of my 193 countries came directly from observing a DX spot. That was when I was check-

ing out some links on my web site and happened to notice V51AS was on 30M at a time I knew I could work the west coast of Africa fairly well. I went to my shack in the other room and made the QSO easily.

I feel that using DX spotting is like this analogy. I love fishing, and especially love catching carp. But suppose I went out and caught some carp, brought them home and put them in a pond in my back yard. Then I could go and catch a carp any time I wanted to, but would that be enjoyable? No. The effort to hunt out that good spot in the river, use the right bait at the right time, etc. is what makes catching the carp fun. I feel the same way about DX spots pointing out a DX station to me and think it lessens the thrill of working the DX.

Keep in mind though that my aversion to spotting is only personal and I have nothing against those who do use it, and I don't recommend not using it. It's your personal choice. In fact I may have to start using it myself some day if I want to get well beyond 200 countries. I have links to the DX Summit spots in the DX section of my web site if you want to use them. Also if you are unfamiliar with DX spots, that would be a good place to find out about them.

Since I'm near the end of the column here I'll stick with the DX topic and put off my other thoughts until a later column.

If you're a QRPer, 2001 may be the last really good year to work some choice DX as many signs are in that sunspot cycle 23 is past its peak and on the decline now. Perhaps the main sign is that the Sun's magnetic field has reversed its polarity, something that generally happens near the peak activity point of a cycle. So don't delay, get on the bands now and chase that DX if that is your wont.

I promised my URL earlier in the column so here it is (they are): [www.qsl.net/k3wwp/](http://www.qsl.net/k3wwp/) or [www.alltel.net/~johnshan/](http://www.alltel.net/~johnshan/) Both are identical mirror sites. If there is anything you'd like to share with me, send me eMail to [johnshan@alltel.net](mailto:johnshan@alltel.net) or regular mail to John Shannon, 478 E. High St., Kittanning, PA 16201-1304. Till next month 73 and good DXing. -30-

## HOW I TAUGHT MORSE CODE FOR AN X-FILES EPISODE

By Robert Ginkowski WA6CW

Working as an actor here in Hollywood, I had the opportunity to teach some Morse code to one of the X-Files stars for a recent episode. When I heard they were looking for someone who knows Morse code, I jumped on the opportunity to serve as a Morse code technical adviser. By the time you read this, the X-Files episode entitled "4-D" should have aired on 9 Dec. 2001. There is a scene in this episode where the character John Doggett (played by actor Robert Patrick) is lying paralyzed in a hospital bed. Unable to speak, he taps out in Morse code, using his finger, a single word: "LUKESH". The character Skinner copies the message on a pad. If the episode aired without too much editing, there should have been a close up shot of Doggett's finger as he tapped out those 6 letters on the bedsheet and some brief dialogue about the Morse code.

When I took the job, I wasn't certain what they wanted. I thought perhaps they wanted me as an actor to work a Morse key in a scene. I also thought maybe I would just be teaching someone the code or how to correctly send with a key. So just in case, I brought my MFJ Morse Code Tutor and the ARRL book "Morse Code the Essential Language" with me to Stage 5 at 20th Century Fox Studios. When I arrived on the set, I learned that the director wanted me to teach starring actor Robert Patrick how to accurately tap out the name "LUKESH" in Morse code with his index finger. How lucky I was! The last three letters "E" "S" and "H" are easy to learn. The only difficult ones would be "L" "U" and "K". If he had a problem learning all these letters, I was prepared to talk the director into using only the last three easy letters for the close up shot. I felt confident that anyone could be taught "E" "S" and "H". Hopefully I would be successful in teaching all 6 letters. This was the day before the filming. The actual scene was scheduled for filming on the following day.

While sitting around all morning waiting to meet with the actor, I had plenty of time to prepare

some teaching aids. First of all, I spent a laborious hour or so trying to program the MFJ Morse Code Tutor to continuously play over and over the word "LUKESH". I had forgotten the manual, so this was a painstaking process. I chose a 5 wpm code speed for the scene for a couple of reasons. It was slow enough so that the actor could learn it quickly. Also, since the character was supposed to be very ill, the slower sending speed would be natural. The character was supposed to know Morse code from his military days. He would normally send at a faster speed but the character was paralyzed and ill. So the director agreed that a 5 wpm speed would be perfect. I also figured that the slower code tapping would look better on camera and would be more easily recognized as Morse code by the viewers. I prepared a visual chart with each letter written as dits and dahs to present to the actor. The "L" was written as dit dah dit dit etc. So the chart had L = dit dah dit dit , U = etc. Above the dits and dahs, I sketched the corresponding dots and dashes. I realize that this visual idea is wrong for serious code learning. I know that the code should be learned by sound only. But this visual chart idea seemed like a speedy way to teach someone the code quickly as I knew that there would not be much time. The code rhythm and spacing training would come from listening to the MFJ Code Tutor.

A few hours later, I finally met with the actor Robert Patrick. He recognized me as I had played a guard in a scene with him in another episode just a week ago. But this time my job was only to teach him Morse code. At first Patrick wondered why he had to learn to do the code finger tapping. They could have simply had me or another photo double/actor do the code tapping in the close up shot. Since the close up would only show a hand, no one would know it wasn't his hand. But the director wanted the actual actor to do it himself. After I showed him quickly what he had to do, Patrick realized that it would not be all that difficult and was ready to go for it.

I instructed Patrick to tap his finger quickly to represent a dit and hold his finger briefly down to represent the dah. Looking at the visual chart

I had made, we tapped out the 6 letters together a few times as I vocalized the dits and dahs. Patrick is a bright actor as he quickly learned to distinguish and organize the short and long sounds. To my delight, he even quickly picked up the more difficult letters: "L", "U" and "K". In the first few attempts, his rhythm was very choppy but improved quickly. "Keep the rhythm the same and pause longer between each letter", I kept saying. "Don't be afraid to exaggerate the pause between each letter" I repeated. Next, I played the word "LUKESH" at 5 wpm from the MFJ Morse Code Tutor so he could hear it with perfect spacing and rhythm. Patrick said "come to my trailer, I want to record that". We went to his trailer and he made a recording of the word "LUKESH" several times into his tape recorder. He practiced doing the code tapping a few times along with the tape recorder playback. This immediately improved his rhythm. He got it! It looked good! All this coaching took only about 20 minutes. He was going to study the chart I had made, listen to the recording and practice before the actual filming the next day.

The next day I returned to Stage 5 at 20th Century Fox Studios to watch the filming to make sure he sent the code correctly. Due to Patrick's busy schedule, I only had a brief one minute meeting with him during the afternoon. He tapped out "LUKESH" for me only once and it was perfect! Hopefully he had done some homework. My only comment and last words to him were "Perfect and don't be afraid to exaggerate the pause between each letter." This advice was to insure that he would not run the individual letters together. So now there would be several more hours of just waiting until the scene was scheduled for filming. I was hoping that he had done some practicing and that the mere 21 minutes of coaching was sufficient.

Finally, just after midnight, they were ready to shoot the scene. It was show time! The director placed me in front of a special video monitor which showed what the film camera was seeing through the lens. I would be watching Patrick's Morse code performance on that video screen. This was the last scene at the end of a very long

day, so they decided to try a "take" without any rehearsal. They also decided to roll two cameras at once to save time. One camera would film the close up of his finger doing the code tapping and another camera was to photograph his facial expressions. I watched this first take and it was a disaster! Patrick's rhythm was wrong and he seemed to have forgotten everything. I looked at the director and shook my head. Patrick also knew he had screwed it up. It was then suggested that the Morse code finger tapping shot be done separately so that the actor could concentrate solely on it. The crew prepared for a second take. This time I watched as he perfectly tapped out "LUKESH L". It was perfect except he began again by sending another "L" at the end. This was probably due to the repeating MFJ Tutor tape recording he was hearing in his head as he automatically began sending the word again - beginning with the "L". I told the director that it was perfect except that an additional "L" was tapped out at the end. Since this was the last shot of a very long day, the cast and crew were anxious to go home. So they accepted the take and it was a "PRINT". Most likely the close up of the finger tapping would be shortened anyway for the final cut. So the additional "L" at the end was not a problem and could easily be cut out. Also, it was reasoned, that the additional "L" could mean he was beginning to send the word again - a second time and that's OK too. So the performance was declared good.



After the usual thank yous, Patrick graciously agreed to pose for the photograph of both of us you see here. (Photo: Left: Rob WA6CW, Right: Actor Robert Patrick)

I am writing this before the episode will air, so I have not seen the scene yet. Hopefully the finger tapping close up will not be cut out or cut too short and will look great. If you happened to miss the episode, I am sure it will rerun again. Check the X-Files web site for rerun times and stations. It was a fun and challenging experience. Often Morse code is not accurately portrayed on the on the screen. So I am thrilled the director demanded accurate Morse code for this scene. And you know what, I actually got paid for doing this.

### **From The Tampa Tribune**

Preston (Moose) #2652 sends this little article along, showing that Hollywood often imitates life -- and that Morse code can be very valuable. "A hospice worker was helping a woman whose husband was dying of ALS (Lou Gehrig's Disease). He was in the final stages, and the only movement he had left in his body was the blinking of his eyes. The hospice worker understood Morse code, and began communicating with the man, a Navy veteran who also knew the code. She taught the code to the man's wife, and once again they could talk.

### **FISTS Awards**

Now that Dennis K6DF has taken over the responsibility of issuing all the awards for FISTS, we thought it would be a good idea to have a column in the Keynote about the awards, as well as recognition for those who earn them.

We didn't always have this information before, so I didn't want to publish the names of just SOME of the award achievers, and potentially leaving someone out by mistake.

Of course, the purpose of FISTS is not to just earn certificates, but to get on the air and make

friends. "Hit and Run" type QSO's are discouraged, except during the Sprints, of course. Few things are more demoralizing for a new FISTS than to be pounced on and once his number is gotten, get a "tnx 73", only to have the pouncer call CQ FISTS on the same spot in the band.. So please keep in mind that there is a fellow FISTS on the other end of the QSO, not just a new number for your collection! End of lecture from Nancy, and on with the column from our new WOFAM (World FISTS Awards Manager) Dennis.

+++++  
The FISTS Awards column is new to the Keynote, and I will try to have something in each issue of the Keynote related to FISTS awards. At the end of each column will be a list of the award recipients for the previous month or months depending on when the Keynote is mailed.

The Millennium Award will still be available up until Jan 31, 2002: If you wish to apply for the Millennium award, please do so before the end of Jan 2002. Remember, the Millennium award is for contacts you had with Diamond Award holders only during the year 2000.

You may apply for FISTS awards via e-mail, after the mess with @home.com is straightened out (Dennis's OLD email address of k6df@home.com is no longer valid due to the bankruptcy of Excite@home.com). Watch the Keynote and the web page for the new address to use to submit your award application. Microsoft Word or Excel files are best, or you can send your log.as a text file. Sending your log in via e-mail is faster and easier for me to keep records. I am trying to cut down on the stacks of paper logs.

When applying for FISTS awards, please include your name, call, and address as well as the name of the award you are applying for. Also, ... Please check your award applications carefully for "DUPES" before submitting them. I have had to delay several award applications because of excessive "DUPES"

awards, please send a letter via regular mail and I will answer it ASAP. I try to get awards on their way to you within two days of receiving your award application.

73, Dennis K6DF, FISTS Awards Manager

---

---

FISTS Award recipients, in alphabetical order, from Sept 1 to Nov 30, 2001.

#### Basic Century

9A0CW, 9A2HF, G3LIK, G3WQU / E4, G14CFQ,  
I2VRF, K1TCI, K4JIF, K8TDM,  
KA9IKK, KCOJKD, KD5GRF, KF0K, KF4TJE,  
K04E, MD0BXX, N3QLA, OH7QR, W1AWW,  
W3HK, W9FFU, WA1ZCB, WB0LBL, WD1V

#### Silver

9A2HF, G3WQU / E4, G4KKI, HB9CHE, I2VRF,  
K1TCI, K4IA, K7DU, K8EIG,  
K9TKE, KDOCA, N5YFC, WB0PYF, WP4IZQ,  
WW1AW

#### Gold

AA1KS, G4KKI, K4IA, KDOCA, KE60IO, NP3K,  
ZL2A0H

#### Diamond

9A2WJ, G4KKI, G4PXQ, K4IA, V01H0, WB2EXI

#### Platinum

AA1KS, AE2L, I2VRF, K1TCI, K3WWP, K7DU,  
K8EIG, KA10X, KD5GRF, KK6AW,  
N5YFC, WB0PYF, WP4IZQ, ZL2A0H

#### Platinum 250

9A2WJ, G4PXQ

#### Platinum 500

K4UK, WA9PWP

#### 1 Way QRP

K4UK

#### Mobile

N0MM, WB0PYF

#### WAS (Worked All States)

KE60IO, KG9LZ, W4FCR, W5DAR, WA7CS

#### Millennium

KA10X

## A NEW AWARD FOR 2002!

Happy Anniversary to us! 2002 is the 15th Anniversary of The Founding of FISTS. To celebrate, we have created a special award. This is going to be a challenging certificate to earn, both for the DX FISTS and the North American FISTS, but it's definitely do-able. The certificate has not been designed yet, but it will be worthy of prominent display in your shack.

The period of time to earn this award will be one year, 2002. QSO's made between January 1, 2002 and December 31, 2002 ONLY will be valid.

To earn this award, you must have a 2 way QSO with:

15 FISTS in each of the 10 callsign zones (0 through 9) - a total of 150 contacts.

40 FISTS in England

40 FISTS in Canada

40 Non-UK, Non-USA, Non-Canadian, DX FISTS

30 Clubs with FISTS numbers

for a total of 300 contacts.

Each contact must be with a different FISTS member. Each FISTS member is counted only once, no matter where they are located at the time of the contact; no matter what callsign they are using. If you contact WZ8C while I'm at home in Michigan and later when I'm on vacation in Costa Rica, you may count only ONE of the contacts toward the Anniversary Award.

Clubs are also only counted once, no matter how many different members you may work. Clubs may be US, or DX.

DX is defined by DXCC rules, which means Hawaii and Alaska are DX for the continental USA.

Once you have a person or club's number, they cannot be counted again toward your total.

Good luck! Hope you have fun and don't forget to do some ragchewing in the process, please!

From the mailbag.....

### On sending Morse Code

I wanted to talk about the quality of Morse code sending one hears on the air these days. By and large most operators form good letters, but often the letter spacing and the word spacing is not quite right. The spacing between words should be 7 units, and between letters, 3 units. A unit is equal to one dot length.

What I am hearing on the air are stations sending with a lot less than seven unit spacing between words, and sometimes no spacing, or only letter spacing between words.

This show this sending would look if you could see it printed out. Hard to read isn't it? Well it's hard to read on the air too. Some operators have good word spacing most of the time but when it comes to sending their call sign, they get in a hurry and send the "de" and their call all together so it comes out like - deve5dc.

The problem of letter spacing is more complex because running two letters together will often form a new letter. For example I hear someone sending the word "and", they run the a and n together to form the letter "p" which then makes the word "pd". Another example is the word "well" with the w and e run together to make a word like "pll".

I have found that years of sending code on a keyboard or a computer is very good because of course the computer sends perfect code and by hitting the space bar between words you get perfect word spacing as well. To do this type of sending you must keep ahead of the buffer so that the spaces are being formed by the computer and not by the operator. Sending with a computer helps your paddle sending as well because you know what good code sounds like. I am not suggesting that everyone should send on a keyboard or computer, but it is good to hear machine sending and then try to imitate it with you paddles or bug etc. By the way I copy all the code in my head and I don't use the computer for this purpose. Unless conditions are perfect the computer does a poor job of copying anyway.

To check your own sending it's a good idea to make a tape recording as you send and see what it sounds like. As dedicated CW operators we should strive for precision Morse at all times.

73 de Jerry VE5DC #4554

+++++

I thought you might be interested in something I learned about CW and its status in the Armed Forces.

Some American military signal intelligence communications operators are formally trained in the art of CW operations. The mode of choice is satellite and in most cases this works very well. HF equipment using voice and data is still used upon occasion but as a backup. No news here, but alas, there is more to the story.

Marine reconnaissance units are at times sent into areas without access to satellite communications. The reason for this being that there are not always frequencies available to all units needing satellite hookups. Lugging around heavy HF equipment when on reconnaissance missions is not often a good idea. A reconnaissance team can, however, make use of a small transceiver, hand key and wire antenna. CW is occasionally used in these situations because, you guessed it, CW gets through when voice and data does not.

Most Third World countries do not have satellite capabilities. The military in these areas must rely upon less sophisticated communication modes. Good old Morse is still used upon occasion by military units in these regions.

So as you can see, good old CW is still there. Trained CW operators are a part of our military still. Where do they get their training? Quite often while sitting on transport ships en route to different regions of the world. With little else to occupy their time, CW practice sessions fit well into the shipboard routine. 73, Paul KJ7LB

*Happy Holidays to all and to all,  
a Good Straight Key Night!*

**73 88.33 Nancy WZ8C**



# FISTS CLUB DOWN UNDER

## Local News - December 2001

Editor & QSL Manager for ZL: Nigel Hardy, ZL2TX, 20 Greenwood Boulevard, R D 1, Otaki 5560, New Zealand  
Tel: 0-6-364-5202 e-mail: zl2tx@ianz.co.nz QSL Manager for VK: John Blake, P. O. Box 2002 KDC, Kingston,  
Tasmania 7050, Australia Tel: 0-3-2674-4296 e-mail: john\_blake@primus.com.au Membership/Awards Liason:  
Ralph Sutton, ZL2AOH, 12c Herbert Gardens, 186 The Terrace, Wellington 6001, New Zealand Tel: 0-4-473-0847  
Fax 0-4-473-0848 e-mail: zl2aoh@radiodx.com or zl2aoh@ihug.co.nz

### SUGGESTED H/F CALLING FREQUENCIES

(160M) - 1.808MHz, (80M) - 3.558MHz, (40M) - 7.028MHz, (30M) - 10.118MHz, (20M) - 14.058MHz,  
(17M) - 18.085MHz, (15M) - 21.058MHz, (12M) - 24.918MHz, (10M) - 28.058MHz.  
U.S. Novice - Sub Bands: (15M) - 21.158MHz, (10M) - 28.158MHz.

### New Members

We welcome two new members this month: -

**ZL2DB-Tony Brown # 9054** comes from Wellington and joins our growing number of members from the capital and surrounds. One of Tony's hobbies is collecting Morse keys of which he has quite a collection. At the last count about 48 different keys!

Tony was mentioned in our Stop Press edition last month.

**ZL1WT-Bernard Westerbaan, # 9065**, lives in Kihikihi, a small town, adjacent to Te Awamutu, the QTH of two other FISTS members. He says - "I'm looking forward to doing more on CW and have put out a call, to get a side swiper? Mechanical bug of some sort! I don't want to use an electronic keyer yet, as sometimes I'll be using an FT200 as well as the TS430S (club rig). Have been listening on the bands but currently they are quite noisy, or down a bit.

### VK / ZL MEMBERS NEWS

**Our Congratulations to Ralph, ZL2AOH, on achieving his GOLD and PLATINUM AWARDS!**

Thanks to **ZL2PG-Keith-9045**, **ZL1ATW-Matt-9010** and **John Blake** for donations received. These are greatly appreciated. John has a ring round 12 February 2002 on his calendar. That's the date he has booked for his Morse examination. Good luck John - May the Morse be With You!

**ZL3HAM-Tony # 9015** reports on the progress setting up his equipment at his great QTH out there on the Canterbury plains ...the shack is virtually finished and the tower is up. I was going to put the Cushcraft A3S up but I was recently offered a good second-hand 5-element TET-Emtron HB35C beam, so I bought it at a good price. I'm just waiting for a new mounting bracket from VK land and with the help of a cherry picker we can finally furnish the tower. I constructed a remote 4-way antenna switch, which is up and working and will enable me to "play" with various wire dipoles as well as the beam. It won't be quite as good as Quartz Hill but should be acceptable all the same.

**ZL1DD - Barry # 9029**, recently hosted Nico PA0MIR, and his XYL Mirelle, whilst they were touring New Zealand for a few weeks by car. Barry runs uses his home as a guest - house on Waiheke Island, just a short ferry ride into the centre of Auckland. ( See Web Sites below).

He doubts if the lower Morse requirement will bring the flood of new hams that the Anti - Morse brigade predicts. He thinks the worst outcome could be a lowering of Amateur Operator Culture, to be replaced with CB style chatter on the bands. (Heaven forbid, the thought makes me shudder - Ed).

Barry is quite pleased with the response to the N.Z.A.R.T. 1<sup>st</sup> Straight Key night, held recently on 80 Metres. He has gone to a lot of trouble to make a rather special Certificate. All those who took part and entered a log, will receive a personalised one.

**ZL2ZLW - Iain # 0012**, comments, now that the General Licence is 5 w.p.m., watch out for the pressure to reduce band allocation for CW to accommodate all those who upgrade and never use CW again!

My Morse key and Oscillator sit on the desk and get some exercise, when the mood takes me. Funny thing is that the first thing I send is " GKB - GKB - GKB". All wishful thinking, I guess!

**VK3DBD - David # 3756**, sent the following report on Straight Key Night. " For once I remembered and fired up the rig on the dot of 0700z. It was very dead indeed and I had to switch antennas to check the 80 metre, dipole hadn't fallen down. Just after 0800z I managed to work ZL1AIH, who also told me the format of the event, followed by others. The idea of SKN seemed to work in principal and brought a few onto the band - It is normally pretty dead in the evening. Nice to hear so many ZL's at one time. It does show that it can be done!"

**ZL1ANY - Stephen # 9055**, is looking for a "Code Partner", to have regular CW rag - chews with, and improve his speed. He currently is around the 21 - 22 w.p.m.

**VK9KNE** - although not a member, (more is the pity), has been worked on 14020kHz. He is a Polish Operator,

currently working on Norfolk Island.

**ZL2TX - Nigel # 9040**, quickly slung up an end fed 84 ft wire for the Straight Key Night, maximum height only 30ft. Must admit that I don't work 80 metres very often, however I had a lot of fun, having dusted off my S.G. Brown straight key. Was very surprised to receive a reply from FW5ZL on Wallis Island, during the event. After three hours of sending, even my wrist began to ache! Missed out on VK3DBD who did not hear me call, possibly due to QRM. Looking forward to next year's event!

**ZL2AOH - Ralph # 1073**, brings up a good point when he comments on Computer Generated Morse. It allows disabled operators with arthritis or even more serious conditions, to send Morse. However, he adds that Computer Morse reading programmes are a lot less effective than the Computer between the ears!

### OVERSEAS MEMBERS NEWS

**Our Congratulations to Stan, K4UK, on achieving his QRP CENTURY and PLATINUM 500 AWARDS!**

**K4UK - Stan - # 2934**, has had to enlist the services of two extra people to sort FISTS QSL Cards. So far during the year 2001 through to October they have dealt with a staggering **34,432** QSL cards. These are just cards to and from FISTS members! The mind "boggles" when one thinks, how many cards the A.R.R.L. Bureau handles each year! Updated figures for the FISTS bureau, can be found on the W4FCR Web Site. VK/ZL cards form a very small part of this operation, as can be seen!

**M0AVW - Chuck # 2896**, has let it slip, that his good XYL, Mandy, does most of the work for FISTS members, sorting QSL cards and filing them. Apparently she seems to think us FISTS guys, are all MAD! Chuck included? She could be correct, but from us all, keep up the good work Mandy, and "Thank you!"

**TF3DX/P - Villi # 1658**, conducted some very interesting tests to New Zealand on the 27<sup>th</sup> October, using a disused Rhombic antenna, each leg 200 metres in length, 40 metres high. The antenna was due for demolition, however Villi says, that maybe, they can have it deferred until absolutely necessary, enabling other Icelandic Amateurs to experience a big antenna. Quote: -

"This antenna was built around 1950. It was aimed at London and used to improve the overseas telephone service, that was run on Short Waves, until a submarine cable with sufficient bandwidth was laid a decade later. From then on, they used this Rhombic, mainly for Air Traffic Control purposes."

"For the tests, I had to reverse the direction from London to ZL short path. We terminated the cable running to the Radio Station in a dummy load. At the South End I cut the wires to the original termination at ground level, feeding the array through a 600 ohm Balun. There was only about 5 metres of RG-58 running from the balun into my car."

The first QSO was with ZL2TX/QRP, both 5 watts. His RST439 / My 569. Later at 0723 UTC, I worked ZL1DD using 230mW receiving the following reports: - ZL1DD(339), ZL2TX(329), ZL2AOH(219).

For the tests, Villi - tried three power levels - 100 Watts, 5 Watts and 230milli-watts!

**I2VRF - Gian # 8325**, writes that he is now 69 and retired. He says, I am now an invalid, suffering from a rare muscle disease (without therapy), so I have much more time for Amateur Radio, Hi! (great to receive some news from Italy, thanks Gian - Ed)

**K7FD - John # 2420**, writes : " Hello Fists friends, I will be concentrating on and around 10.118MHz each evening from 0200-0500Z looking for FISTS contacts. If you hear my CQ's from my homebuilt SST, I'd be very pleased to put you in my log. I QSL 100% via the FISTS bureau, or e-QSL if you prefer. 1.9watt SST into a droopy dipole @ 50'. <http://home.teleport.com/~cqdx/sst.htm>

### WEB SITES OF INTEREST

Greg Laplin, N9GL, Chairman of the A.R.R.L. RF Safety Committee, posts his "RF SAFETY Column", on the Web. Go to: <http://www.remote.arrl.org/rfsafety/lapin/2001/08/0/?nc=1>

Barry's, Guest - house and Amateur Radio Set up, (ZL1DD), on Waiheke Island. [www.waiheke.co.nz/signal.htm](http://www.waiheke.co.nz/signal.htm)

The Franklin County Amateur Radio Club issues the "Spoon Award" as mentioned by Stan, K4UK # 2934. This is issued to members of the local club honouring "Senior Moments" and "Bonehead Actions". This hilarious award has already been issued to two, well known FISTS members, and I believe a third award is about to be issued down under! Also by going to ELMER CENTRAL, there is some very useful information on Amateur Radio Lightning protection and a loss chart for Cable Attenuation (dB per 100ft). [www.qsl.net/w4fcr](http://www.qsl.net/w4fcr)

The Quartz Hill User Group, Wellington, New Zealand has a fascinating site (Call Sign - ZL6QH) which will make most drool, with envy. Fancy operating with Rhombics and Vee Beams, 20 metres high. Articles have appeared in several magazines about this station, here is your chance to view the work done by this group. I am told that the Web Site is not completely finished. (Thanks to the Group and also the Wellington Amateur Radio Club, not forgetting the author Mike Kerr, ZL2BCW) [www.zl6qh.cjb.net/](http://www.zl6qh.cjb.net/)

Tony, ZL2DB, directed me to the very impressive site of "The Telegraph Office" by Neal McEwan, K5RW. This site is a photographic reference for Wire and Wireless Telegraph Key Collectors. Go to:

[http://fohnix.metronet.com/~nmcewan/photo\\_gallery.html](http://fohnix.metronet.com/~nmcewan/photo_gallery.html)

### KCJA (Keymen's Club of Japan Award) Certificates

Most of us have worked numerous Japanese stations. There are plenty of JA CW operators populating the bands. They are usually good operators, courteous and friendly and are good at responding with QSL cards. One way of adding interest to these contacts is to apply for a KCJA certificate issued by the "Keymen's Club" of Japan. You may also learn a bit of Japanese geography!

There are 47 Japanese prefectures. One contact with a station in a prefecture on one band counts as one point. (For example, you may work dozens of stations in Kanagawa prefecture on 20 metres, but only one can be claimed.) Certificates are issued for 100 points and stickers are issued for each additional 50 points beyond that. Any amateur band may be used and satellite communications are regarded as a separate band. The information required in the list of contacts is: Call, Date, Time, Band, Mode, RST. The charge for the certificate is 5 IRCs. Contacts may have been made under different call signs if the licensee for all the contacts was the same. QSL cards have to be checked by another radio amateur.

Further information can be obtained from their web site <http://www.jarl.com/kcj> or from The KCJA Awards Manager, Ichio Ujii JH7FQK, 162 Shionosawa, Kohata Towa, Adachi, Fukushima 964-0203, Japan

### Russia Rejects End To Code Licence Tests

The Russian Federation supports the retention of mandatory Morse code licence tests for the Amateur Service. In a position paper sent to the International Telecommunications Union (ITU) it spells out a number of reasons for its stance. Among those is the belief that the code is a primary point of difference between the Amateur Service and CB radio. The Russian Federation also advocates the retention of ITU RR s25.3 that prohibits third party traffic out of concern of commercialisation of the Amateur Service, and it does not fully agree with a proposed change to s19 intended to give more flexibility in the formation of amateur callsigns.

### A "FISTS" - Tale of Woe or Oops!

Last Thursday I went to Khandallah, a northern suburb of Wellington, to have lunch at a local hostelry with a Ham friend. I had one bottle of the brown stuff - honestly!

On the way home, the low fuel warning light flashed on and off, so I pulled in to my usual filling station. There were no assistants available, as the place was exceptionally busy. So I started to fill the tank myself.

I thought that it wasn't filling as fast as usual and thought that it was related to the fact the place was so busy. After a while it suddenly dawned upon me that, instead of petrol, I was filling the tank with diesel fuel. As the tank had originally been almost empty, I thought that I had better top up with petrol to give the engine some chance of operating!

So red faced, I paid up at the desk and proceeded to drive towards the garage where I get the car serviced regularly. For the first few hundred metres she ran nicely, but gradually she began to cough and splutter and poured out a persistent plume of thick black smoke. I was the recipient of many glares, as black as the smoke and my journey across the city was not a happy one! Fortunately, there were no "Gendarmes", around.

The fellows at the garage had a good laugh at my expense but assured me it wouldn't take long to fix. So I left the car there and returned home by public transport.

They rang fairly early the next day and I picked up the car that was now behaving as if nothing had happened. They had drained the tank, blown through all the fuel lines, checked the filters, replaced the plugs and filled her up with petrol. The bill for that, plus the wasted diesel/petrol mix all came to over \$NZ 200.

I'll be extra careful in future, you bet. I can't afford not to be! Very 73's de "The Diesel King"

(The above is a member's true story. To save the person further embarrassment, I have omitted names. Good job there were no "Gendarmes" around or a hefty fine might have resulted! - Ed).

### Editor's Comment.

I read with interest a comment by Carl, AB7YW # 6541 in the American Keynote. He was recently working on the 15 metre suggested calling frequency and was answered by several European members. His problem was that he could not read them due to QRM from other American Stations. He mentions that the suggested frequencies, be used a calling frequency only and stations should QSY on making contact.

Although we "Down Under" don't have the same problem with congestion that occurs overseas, I would take Carl's suggestion one step further and say why not have a band of frequencies say 10 or 15khz in each band in which to call and reply. This would encourage stations to tune up and down listening for a CQ Fists Call.

I would be interested in member's comments!

### "KEYNOTE" and "FISTS DOWN UNDER".

Due to the holiday season there will be no U.K. Keynote for December. The next issue of FISTS "Down Under" will be in FEBRUARY and will include member's names, call signs and "FISTS" - numbers. The January "Keynote", will be forwarded with this issue. The QSL Bureau will continue to function during the holiday period, so keep the cards coming!

To all our members and their families, have a MERRY CHRISTMAS and a HAPPY NEW YEAR! 73's de Nigel, Ralph and John.

2.2k PTT - T/R Switch

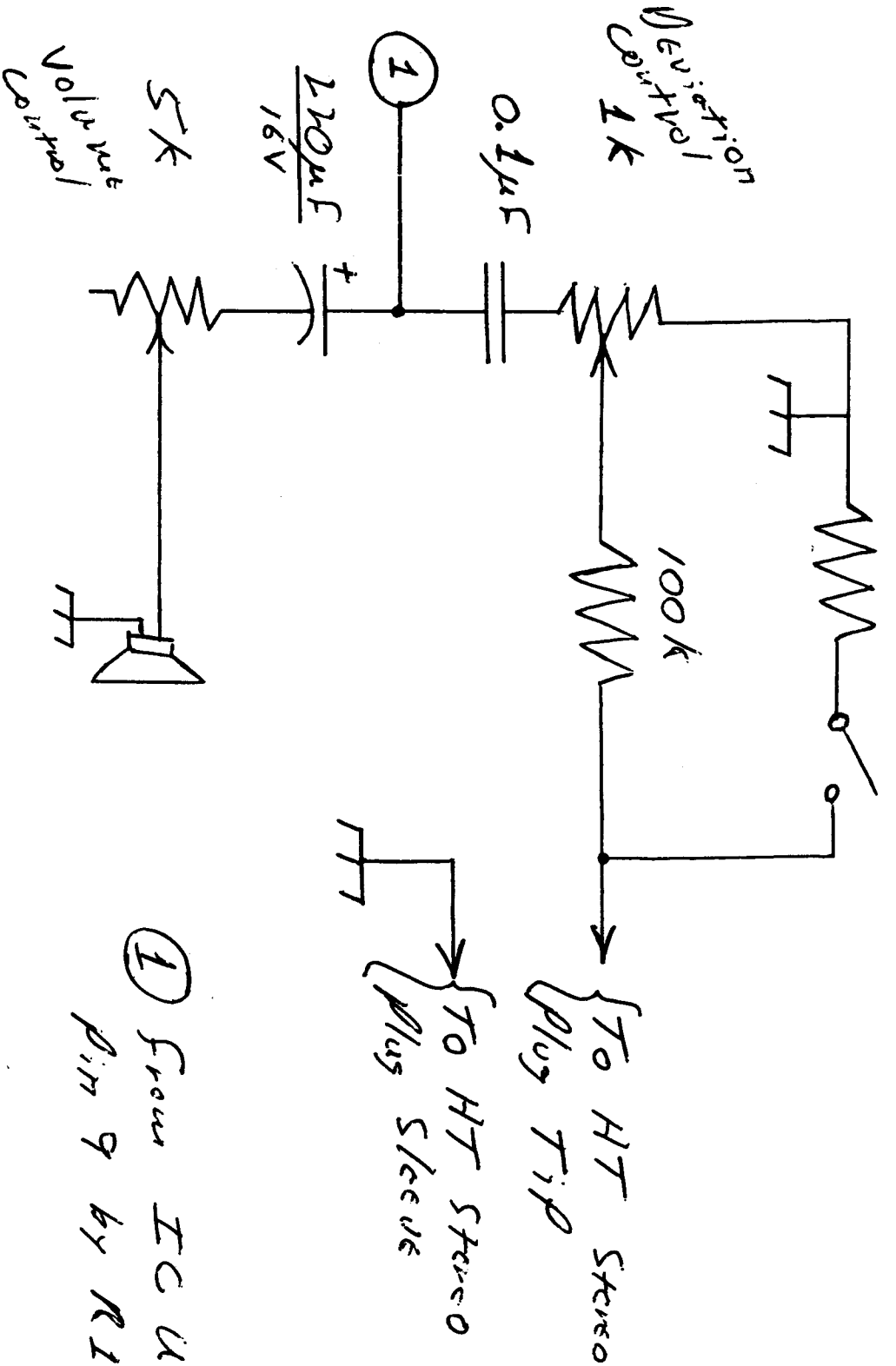

① From IC U2  
Pin 9 by R17

Mike G/NSSTY/11282

21 Nov 02



# KEY NOTE



Sec: E. (Geo) Longden, G3ZQS. 119 Cemetery Rd., DARWEN, BB3 2LZ, England. 01254-703948  
 http://www.asel.demon.co.uk/fists-hq/ or http://www.smartgroups.com/vault/fists/  
 E-Mail: fistl@btinternet.com webmaster: webmaster@asel.demon.co.uk

**OFFICES**

**QSL Manager: M0AVW**  
 32 Woodford Walk, Harewood Park, TS17 0LT

**PRO: G4YLB, J.A. Welsh**  
 3 Minster Cresc, DARWEN, BB3 3PY  
**CONTEST MANAGER: M0CLO**  
 86 Coldnailhurst Ave, East Perry, CM7 5PY

**COMMITTEE**

**Chairman**  
**Vice Chairman**  
**QSL Manager**

**P.R.O.**  
**Rally Coordinator**  
**Secretary**  
**Committee**

**G4XHZ**  
**G4YLB**  
**M0AVW**

**G4YLB**  
**G4PPG**  
**G3ZQS**  
**G4MZS**

**NETS**

**Sunday US: 0100Z on 14058**  
**Friday: GX0IPX/P 1930 ON 3.558 (+/-)**  
 also at 2200, on highest usable band

**DX 14/21/28.058 on the hour for 15mins**  
 Pse keep watch on all Novice allocations  
 UK Net Controls use GX0IPX/P

**SUBS: UK £5.00, EEC £7.00. Others £10.00.** Your renewal date appears on the mailing label and your anticipation would be much appreciated.

**Up-dated listings** may be obtained from HQ. Please include 3 2nd class stamps to cover return and running costs

**Lapel Badges, £1.50 incl.**

**Fabric patches £2.50 incl.**

**QSL Cards £7.00 per 100 or £10.00 per 200 (UK and EU pse add £1.00 for p/p. DX members - on advice.**

**Personalised stickers £1.00 per sheet of 65. Max order 5 sheets.**

**Please include your CALLSIGN on all correspondence.**

**Useful contacts:**

**M0AVW 01642-869619 <spence5@ntlworld.com>**

**M0AYI 01207-283192 <m0ayi@netscapeonline.co.uk>**

**All outgoing QSLs to M0AVW (address on banner).**

**All UK members send stamps and labels (no envelopes necessary) to the appropriate sub-manager as below:**

**M or 2 calls (Except for Wales) M0AYI. 7 Tynedale Terrace, Annfield Plain, STANLEY, DH9 7TZ.**

**G0, GM0 etc (Except GW0). G3JRY. 3 Rochford Cresc, BOSTON, PE21 9AE**

**G3, GM3 etc (except GW3). G0UQF. 2 East St, Darfield, BARNSELY, S73 9AE.**

**G4, GM4 etc (Except GW4). M5AAQ. 6 Central Ave, SHEPSHED, LE12 9HP.**

**G2, G5, G6, G8 (Except for Wales) and ALL special (GB etc) calls to M0BPT. 38 Wheatley St, WEST BROMWICH, B70 9TJ.**

**All members in Wales. GW0SGG. 14 Heather Cresc, Sketty, SWANSEA, SA2 8HE**

**EU/DX Members: IRCs or UK Banknotes to M0AVW. US dollars to HQ. Club will provide envelopes. Any excess over subs from non-UK members will be regarded**

**GREETINGS**

Welcome to the tail end of October people. Old tempus keeps on fugiting and now with the onset of Autumn and ankle deep in a yellow to red carpet of discarded leaves, conditions on the bands have taken a turn for the better and it is always a good policy to check HF from high to low. Doing this the other day, activity was noted on 18MHz and a number of stations were worked including HL4. No amount of twiddling with the ATU produces anything like a decent match with the W3DZZ so the mag loop is a blessing.

Sorry I am a little adrift with this Keynote - do my best but most of you will be aware of the domestic conditions here so I do hope you will make allowances.

Our Chuck, M0AVW, has finally replaced the PC which went ape following a severe infestation. He asks me to remind you of the caps which are available.

Andy, G0JLX, is off to Saudi Arabia on business for a couple of weeks and it is likely that the Keynote via snail mail will arrive ahead of the digital version. I understand he has circulated all on the list with this advice though to be truthful, had I managed to finish this earlier, there would have been no problem.

Those of you on e-mail (a rapidly growing band) are reminded to ammend the address for Andy, G0JLX, on their address books. It should be <webmaster@asel.demon.co.uk>. This is to permit him to discriminate between FISTS business and other matters.

**CALL CHANGES**

Please note the following ammendments to the listing: M5AIA. 7136 (Brian) is now G0SWL whilst M5ABM, 6425 (Hughie) becomes M0HMS. John, M5AAH is now M0YLE.

You can bet that many of the RNARS exhibition stations are a bit sore at themselves for not spotting M0HMS and booking it in advance for one of the museum ships.



## THE SECOND QRP-PEdition

The UR-QRP Club is planning to hold its second QRP-PEdition to plateau Ai-Petri, in Crimea between 9 and 17 of December, 2001 initiated by Igor Grigorov, RK3ZK. The expedition is dedicated to all Pioneers of the Radio. One of its aims is to commemorate the centenary of the 1st radio contact of G. Marconi across the Atlantic Ocean. In fact this first transatlantic radio contact made way for the radioamateur movement in the whole world. Call, EN100GM.

Those who wish to join our QRP-PEdition are welcome. We shall also accept with gratitude any technical or financial support. Information and photos about the first UR-QRP Club expedition can be found on Internet:

<http://www.qsl.net/us1rch/urqrp/rk3zk/aie.htm>

72/73! Peter Grytsay, US1REO FISTS # 5593

E-mail: us1re0@ne.cg.ukrtel.net

## QSLs AND SWLs

I don't think we catered for SWLs when allocating QSL managers so when Chuck came head on to one he thought it best to handle it and the other SWL traffic:

*Hi Geo , Could you let it be known in the key note, that I am the manager for all FISTS SWL , and for them to send all out going QSL's to me along with their address labels and stamps .*

*Best 73's Chuck*

## FROM F5NQL

Maurice picked up the ARRL news letter and kindly forwarded it me from whence I extract the following item:

The 40-meter band is currently the focus of an effort supported by the International Amateur Radio Union and ARRL to obtain a 300-kHz worldwide exclusive allocation. Most of the world does not have access to the 300 kHz-wide swath from 7.0 to 7.3 MHz that US hams enjoy. In the rest of the world, the upper two-thirds of 40 is dominated by broadcasters. This issue is on the agenda for the 2003 World Radiocommunication Conference <<http://www.arrl.org/announce/regulatory/WRC-03/>>. One suggested remedy would shift the allocation downward to create a 300-kHz worldwide band at 6.9 to 7.2 MHz.

The 80/75-meter band—3.5 to 4.0 MHz—is exclusive to the Amateur Service in the US. Elsewhere in Region 2 hams have exclusive status from 3.500 to 3.750 MHz and share the rest of the band with foreign Fixed and Mobile services on a co-primary basis. Amateurs in Regions 1 and 3 share parts of the band with Fixed and Mobile. There is no amateur operation allowed above 3.8 MHz in Region 1, which includes Europe.

The 1.8 to 1.9 MHz segment of 160 meters is exclusive to US amateurs. Hams in the US are secondary on 1.9 to

2.0 MHz to the primary Radiolocation Service (government and non-government).

A table of US Amateur Radio allocations is available on the ARRL Web site

<<http://www.arrl.org/FandES/field/regulations/USbands.pdf>>. The "Considerate Operator's Frequency Guide" details band plans for Amateur Radio <<http://www.arrl.org/FandES/field/regulations/conop.html>>.

The ARRL Letter is published Fridays, 50 times each year, by the American Radio Relay League

## G0, G10 AND G10 QSLs

*"To all G0 G10 G10 Fists members: Do you have stamps/labels deposited with your G0 sub-bureau for forwarding your incoming QSL Cards? There are around 900 cards waiting here (some of them very attractive/expensive) for some 120 members who do not have postage lpdged.*

*The following members have large numbers to collect : ADE BCT JWB NAN/6Y5WJSVX VQW WAQ GM0MFE The others have ammounts varying between 1 card and 1 packet of cards.*

*As from the publication of this information, all currently uncollected cards will be binned after 6 months. From, then, cards not collected will be binned 6 months after receipt. Please advise the stations that you are working if you do not wish to receive cards.*

*Thank you (in anticipation) for your co-operation. Selwyn Auty G3JRY G0 QSL Bureau". Vy 73 de Selwyn*

## CQ MAG AND ALLOCATIONS

Maurice, M5MQL is just one of many who complained to CQ about SSB and data-mode incursions into the CW segment of 40m. I extract the following from a reply: You make two basic points to which I would like to respond, and then I will need to get back to working on the next issue of CQ:

1) The need to promote voluntary compliance with the IARU bandplans.

2) CQ's position regarding CW.

1) I agree that more could be done to promote compliance with the bandplans, and I think your suggestion is excellent that we publish an article explaining what they are, how they differ from region to region, and why they are important for peaceful coexistence on the ham bands. Of course, this will not ensure significantly greater compliance, but if even some people change their operating habits as a result, it will be successful. I will put this article on my list for a future issue.

2) Your perception that CQ is anti-CW is wrong. We are very much pro-CW, and we certainly do not think CW ops are a negligible quantity nowadays. We see the logs for the CQWW CW and WPX CW contests. The number of entries grows each year.

You cite CQ's comments to the FCC regarding amateur license restructuring in the United States as proof that we are anti-CW. I have just reviewed those comments (they were written three years ago). Our only comments regarding CW were that we felt the old license structure relied too heavily on CW proficiency as an overall part of the licensing requirements, and we proposed reducing the required code speed on licensing exams, either to 5 and 10 words per minute, or to a single speed of 5 wpm, which is what the FCC adopted. We have never called for the elimination of the code requirement.

That said, it is clear to us that the tide of world amateur opinion has shifted, and that the majority of amateurs no longer believe that demonstrating code proficiency is a valid prerequisite for holding an amateur license with HF privileges. Even the International Amateur Radio Union has adopted his position as its policy.

Does this mean that CW as a popular operating mode is about to go away? There are many ardent CW enthusiasts who seem to believe that, if code proficiency is no longer required for licensing, then no one will learn it anymore. We disagree, and so do our readers. We feel that people will continue to learn CW as long as it can add to their enjoyment of amateur radio. Many people simply enjoy using CW and will continue to do so; some DX is accessible only via CW; people with limited stations will work more stations, farther away, using CW than SSB. Even VHFers who want to work moonbounce or meteor scatter will benefit from learning CW.

Let me share with you the results of our September reader survey, about our readers' CW operating habits, that will appear in our January 2002 issue: More than half of our readers consider their CW proficiency level to be "advanced" or "expert" and nearly two-thirds operate CW at least half the time they're on the air. The most popular CW activities are DXing and rag-chewing; and more than half say their primary reason for operating CW is because they enjoy it. Finally, more than half also answered yes to the question of whether they thought they'd have learned CW even if it wasn't a licensing requirement.

This shows a very high level of support for CW among our readers, and we believe it will continue to be a strong and popular operating mode, whether or not it continues to be a licensing requirement. And remember, we sponsor two of the most popular CW operating events of the year, the CQWW CW and the CQ WPX CW (not to mention the CQWW 160 CW Contest)

I hope this has helped to clear up any misconceptions you may have about CQ's support for CW. Please do spread this among your fellow CW ops in France, so that it is widely understood that CQ strongly supports CW operating and CW operators, and does what it can through its contests to promote CW activity.

73, Rich W2VU Editor, CQ

*(Note from Nancy WZ8C: I hope you take this letter with a grain of salt - our personal experience with CQ Magazine and its endorsement of W5YI and his organization "No Code International" has shown them to be unsupportive of the CW requirement to earn a ham radio license)*

## WARNING

Our Maurice, F5NQL is a positive mine of information and in this case, he advises that a worm virus is in circulation masquerading under the guise of the French REF-UNION. It arrives as a normal e-mail with an attachment REFmUNION.EXE and carries the virus W32.Magistr.39921@mm. Those of you using Norton or most other anti-virus scanners should be safe enough but if you have not yet got round to protecting your computer - lookout!

## WTC SPECIAL

During the events of Sept 11, amateur radio ops supplied communications to assist the various emergency services proving again the value of our hobby in times of need. In recognition of this, the QRZ group (Sussex) will be activating a special event station from 1800 Friday Nov 23 to 1800 Sunday Nov 25 with the call GB4ISE. A copy of the log book will be presented to the ARRL as a token of our support. This information from Stuart, M0CHW.

## PREFERRED QRGs ON WARC BANDS

There has been much confusion over these and a quick e-mail to Nancy detailed the following which are in general use by the US gang: (30m) **10.118**. (12m) **24.918**. (17m) **18.085**. For those of you with 6m, they are using **50.058** as expected.

## 2M CW ACTIVITY

Angie is still active on 2m CW and in-fact there is a group concerned specifically with just this. There is quite a lot of information and Angie invites all interested to contact her at:

morseladyuk@yahoo.co.uk \_\_\_\_\_ or  
morselady@ntlworld.com. She will point you in the direction of the Yahoo group.

## NEW MEMBERS

8338	MM0CAE	Jim
8339	G0TNU	Gra
8340	M5HDF	CLUB
8341	G3HJF	Jim
8342	GM3VTH	Dave 8
343	M0BDB	Roland
8344	M0DRK	Derek

M5HDF incidentally is an additional call of the Midland Contest Group and accompanies G2HDF. Another source of three-pointers for you.

## THE STRAWBERRY BASKET

**OZ1EUO.** Leif sends me a QSL card whose face depicts an ancient inn Hjerl Moor -hope I have got the spelling right Leif - a beautiful thatch roofed building painstakingly drawn by a friend. Well if I ever do get that way, I'll know where to go for a pint!

**G3TVI.** Why is it that so many keys have a miniscule little knob reminiscent of a drawer pull which demands finger tip operation instead of one which permits the more traditional 'fist' grip wonders Rod. He took the handle of a date stamp and modified it to fit. (Photo on next page) Did the same thing my-self with a rubber stamp block Rod and although they do tend to be just a wee bit over-size, it is preferable to the opposite.

**GOPEH.** Tony has got into the habit of signing with TTFN after a good rag-chew. There can't be many of you out there who do not remember this (TaTa For Now) from the unforgettable ITMA shows on the old steam radio. Mayhap it could be contagious 'cos it has a nice 'swing'.

**G3HBN.** Our Jim has been spending a few weeks in the antipodes - VK6 in fact but is now back in the real world. Hope the trip was enjoyable Jim.

**G0UJO.** Merv has the use of the ISWL call GX4BJC/P for December and amongst other pursuits will be the targeting of US stations on 28058.

**GM3LGM.** Bill visited the cardiac clinic in Dundee and was a long way from displeased to hear the consultant say "See you next year". He is now entering his 82nd year and as an ex-sub mariner you could say that fate has looked kindly upon him. Hi.

## ODDS 'N ENDS

### QRP v QRM

Chris (G0IYZ) attended the rally at Donnington where the RA rep struggled bravely against the QRM of some extremely noisy ventilation systems. Despite turning up the wick on the less than efficient PA unit to maximum he was largely lost under the racket. He would have been better using a key/oscillator opines Chris.

### G0HGA Website

Angie, G0HGA has up-dated her website on [www.qsl.net/](http://www.qsl.net/)

g0hga and it is also mirrored on [morselady.topcities.com/](http://morselady.topcities.com/) and would appreciate you calling in.

### G3ZDD and the Whitehouse

Sure he will not have been the only one but top marks to Derek for digging up the address from the internet search engine. His message of sympathy following Sept 11 was forwarded to President Bush.

### G4FAI and sticky fingers

With reference to the structure of the code, Tony mentioned that 20% of the characters originally defined by Sam Morse were included in the final lineup. This should have been 20 characters but as usual, yours truly just wasn't reading carefully!

### G4KKI with ancient kit

Thinking of the 9R59D, Bill dug up his ancient BC221 (wonder how many of today's youngsters know what this is?) and despite being last calibrated by the MOD in Oct 1944, he was delighted to find it was still spot on. I am tempted to say "they don't make em like that anymore" Bill but for sure, they were constructed to last. Hi.

Here are infos received from GIL, F5NOD about the F6KDF ARC activity during the next WWDXCW Contest :

Callsign: TM0DX Crew : F5ROP Fred, DL7FER Felix (Guest operator), F8BWB YI Viviane, F5SIH Eric, F5NOD Gil. The operations will take place from the usual F6KDF's contest site in the Ain department . forwarded by : Maurice, F5NQL, Dx page editor at : <http://www.uft.net>

### Hi Guys

Information received from Patrick FR5FD.

I'll be active for the next CQWDX CW at the end of November in monoop low power class all bands. I am also very active every day.

For the ham community, would you note that I have not and QSL Manager, instead of false informations published in some call books and databases .. The correct information will appear in the next 2002 issue of the Call Book inc, at the end of 2002. Fr5fd.

Forwarded by Maurice, F5NQL, Dx page editor at : <http://www.uft.net> 73 and be lucky.

### The weather hazard

NW3N took a direct hit by lightning recently - did some pretty nasty things to his TS450 and it is feared he may have to send it in for some serious surgery. This was an earlier report and I hope that by now the lad has got things sorted out.

### and solar storms

Not unlike lightning in its effects, I learned recently that there are a number of orbital sensors monitoring excessive solar radiation which it appears occur periodically and



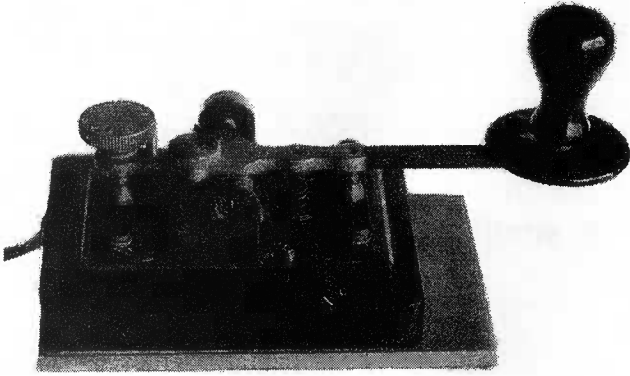

**G3TVI Knob Adaptation**

which send huge waves of ionized particles in random directions from old Sol. There must be very little warning when these occur but I understand that this is sufficient to re-orientate some of the more sensitive hardware orbiting us to shield their vital bits from the effects. You don't believe it? A large lump of Canada was deprived of power on one occasion when the electricity grid system was overwhelmed. It is difficult to imagine that the amateur satellites are thus protected so they seem to be living on a knife edge.

**The woodpecker returns**

Does anyone have any information about this? Shortly after the attack on the World Trade Centre, it was heard for a short period only on 40m and I am told, on other bands also. We could well do without this relic from the cold war.

**No Contest logs except via e-mail**

In view of the number of envelopes which must be delivered to CQ, I was not too surprised that they have opted for e-mail only logs for the CQ World Wide contest. Must take a fair number of aspiring applicants out of the frame but in the light of what has been going on over there since Sept 11 it makes sense.

**The Ladder**

Just in time to remind you that the ladder starts January 2002. Every Wednesday, 0800 - 2200 and although all non-WARC bands are quoted, it is anticipated that the bulk of activity will take place on 80 and 40 metres. I know there a few who feel that the format is not ideal but please do give it a chance and if anything needs to be changed for the following year then M0CLO will have the opportunity to see what can be done.

You have lots of opportunity to work at your leisure so if your contacts seem that way inclined then there is no need to restrict yourselves to quick in/out exchanges - a few additional words would no doubt be appreciated.

**NUMBER CHASING**

It was a little surprising to me because I have never bothered with the statistics and other math involved but from Nancy comes a quote of something in the order of 2% of FISTS members have earned the higher achievement awards.

Makes you wonder where the rest of 'em have got to! In fact, especially over here in Europe or the UK, such activities tend to be restricted to the HF bands and those who use 40 or 80m are generally expecting to bump into members they have worked previously and where the prospect of good natter is the aim. Having said that however,

I do find myself involved in much lamp swinging and general chit-chat irrespective of the band but perhaps it comes with the club call or perhaps because when conditions are suitable, I tend to instigate rag chews.

Please do not think that I am knocking those who are seeking awards (there would be little point in having them if this were the case) but there may well be an assumption that the first-time contact is only interested in what you have to offer. Try an opening first - you may well discover a kindred spirit.

**SILENT KEY**

Although a lapsed member due to illness, I record the death of Ken, G3GPE (7118), 13 Nov/01. ex-Y11 X and other o/s calls, Ken was a member of FOC and TOPS. and a firm CW op.  
My thanks to Pete, G3ICH for info.

**9ACWG**

*I am wishing to inform you with our Club station 9A0CW FISTS-7795. The 9A-CW-G is short of Croatian Telegraphy Group. Our Group was formed in April 1995. We are member of EU-CW-Association.*

**Rules for 9ACWG members award (W-9ACWG-M) award**

*2-way CW contacts with 9A-CWG members after 1st of May 1995 as follows:*

- 9A amateurs..... 10 contacts*
- EU amateurs ..... 6 contacts*
- DX (amateurs outside EU) 3 contacts*
- Award fee is \$ 5 or 10 IRC or 7 DEM*

*You have to send application with GCR list verified from one other licensed radio amateur operator*

**ADDRESS FOR BOTH AWARDS:**  
*Mato Samardzic, 9A3SM*

*Jure Kastelana 20  
HR-10.000 ZAGREB  
Republic of Croatia*

*List of members of 9A-CWG:*

*9A2WJ, 9A2AJ, 9A3SM, 9A2EU, 9A8A, **9A5I**, 9A3UF,  
**K1RH**, DL4FDM, 9A3PA, DL4CF, Z32KV, OK1RR,  
HA3NU, 9A7V, 9A2VB, OH4YR, 9A7AA, **K9QVB**,  
RA6AR, PY1BVY, I7ALE, 9A7W, 9A1AA, ON5ME,  
S58MU, 9A3A/5B4ADA, S51M, BV2TA, DL8KAZ,  
T94GB, ON6CW, 9A4W, T94YT, 9A2OO, DK1WU,  
HA0EQ, UA1CGS, F5PIQ, **GOEBW**, DL8HRW,  
DL3MCO, 9A5O, 9A2TN. The CALLs in bold are also  
FISTS members.*

**Requirements for membership**

*Membership is offered in all operators all over the world, who have the license and are active on at least two amateur bands on CW. They have to be capable of sending and receiving 30 WPM (150 letters per minute) with high standard as operators in technique and clarity and HAM SPIRIT, without use of computers, decoders, keyboards or other helping devices. Test CW QSO should last at least 30 minutes. They have to get 4 proposal for membership in 9A-CWG from 9A-CWG Members, of which one should be from Croatia.*

*Membership fee is paid with the application for membership in 9A-CWG and is for life (\$ 5, or 10 IRCs or 7 DEM).*

*Each member of 9A-CWG gets membership award (diploma) with his membership number.*

*The Secretary of 9A-CWG is Mato Samardzic, 9A3SM, and the President of 9A-CWG is Milan "Daki" Drlic, 9A2WJ.*

*Daki, 9A2WJ*

For news of what's happening in the world of Morse, read "MM"! This unique bi-monthly magazine carries a wide range of articles on all aspects of Morse; past, present and future. If you like Morse, you'll like MM

By postal subscription only. Send for a sample copy £2.50 (US \$5.00 bill) or ask for further details from



Samuel F.B. Morse  
1791-1872.

**Morsum Magnificat  
The Poplars  
Winstanswick  
MARKET DRAYTON  
TF9 2BA, England  
01630-638306 or fax 01630-  
638051**

e-mail: [zyg@morsum.demon.co.uk](mailto:zyg@morsum.demon.co.uk)  
Home page: <http://www.morsum.demon.co.uk>

**FINALE**

Sorry I am adrift again with this letter people. Things sometimes get so glued up at this end that such delays are almost inevitable but we soldier on and I can only thank you for your understanding and support not just of FISTS but CW.

Next month, Nancy will be spending a few days in dry dock for some necessary surgery but she assures me there will effectively be little time lost due to this - we wish her well.

I would normally produce a Keynote in December and skip January due to the postal chaos but the way things are at present, skipping December instead will give me a break which I feel very much in need of. During the next few weeks, I shall be replacing my existing Intel III computer with something much more up to date so everything should be sorted out before the January Keynote is due to be posted.

There are a number of IRCs here at HQ for disposal. 50p each.

Cheers for now people. Hope you all have a fine Christmas and I look forward to seeing you in the new year.

73/88, stay sober (well reasonably) and we hope for a more stable and civilized world in 2002.

Geo



# FISTS C.W. Club Membership Application

Call sign: \_\_\_\_\_ Name used on Air: \_\_\_\_\_

Mailing Name & Address: \_\_\_\_\_

\_\_\_\_\_

\_\_\_\_\_

\_\_\_\_\_

The following information provides a synopsis of the member's working conditions:

Rig(s): \_\_\_\_\_

Antennas: \_\_\_\_\_

Other Clubs Affiliations (ARRL, RSGB, etc.): \_\_\_\_\_

Other Interests: \_\_\_\_\_

Birth day: \_\_\_\_\_ Home Phone: \_\_\_\_\_ Are you visually handicapped? \_\_\_\_\_

E-mail address: \_\_\_\_\_

Please enclose annual membership fee of \$15.00 (US Funds)

Date: \_\_\_\_\_ Your Sponsor (Optional): \_\_\_\_\_

Signature: \_\_\_\_\_

Please make checks payable to FISTS C.W. Club and return to:

North, Central, and South America  
including all territories/islands;

Nancy Kott WZ8C  
POB 47  
Hadley MI 48440-0047  
USA

Europe, Asia, All others;

Geo Longden G3ZQS  
119 Cemetery Rd.  
DARWEN, BB3 2LZ  
England

FISTS CW CLUB, PO Box 47, Hadley MI 48440-0047

**ADDRESS SERVICE REQUESTED**

**YOUR SUBSCRIPTION RENEWAL DATE IS ON YOUR MAILING LABEL**  
in the format of year/month/day

Are YOU due to renew your subs??

NONPROFIT ORG  
U.S. POSTAGE PAID  
Permit 12  
Hadley MI 48440

*WARRIORS*  
By KISS, "Horse" and "Warrior"

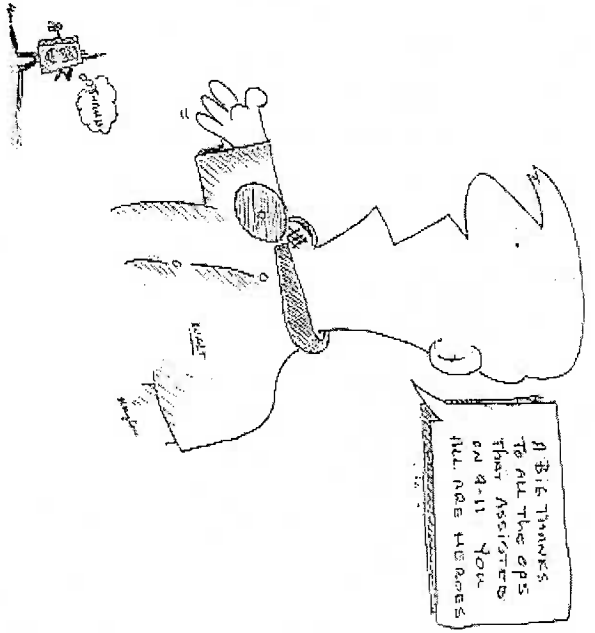

**If you move, PLEASE let us know! Is there a typo on your mailing label? Tell us! The P. O. charges sixty cents if your label is addressed incorrectly.**